



# TECO

Advanced Automation

Controllers for machine, proces,  
building and transport

- No. 1 Czech PLC developer and manufacturer,
  - Brands: Tecomat Foxtrot, Tecomat TC700, CIB Common Installation Bus
  - Kolín, Czech Republic
- Member of PLC Open
  - Support of international programming standard IEC/EN/ČSN 61131-3
  - MO
- About 40 years experience of development, production and service of industrial controllers and automation
- Continual development, backward SW compatibility, Open systém, Full integration in Internet

- Tecomat Foxtrot
  - Flexible PLC on DIN rail
  - Full ekosystem of several central modules and the bus and wireless expansion peripherals



- OEM Foxtrot
  - For manufacturers of Heat pumps and other HVAC products,



- Embedded PLC
  - New approach of OEM PLC

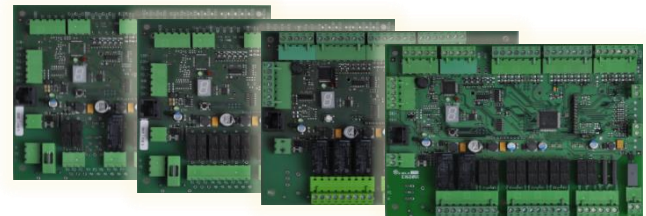

- TC700
  - Big modular PLC for thousands inputs/outputs



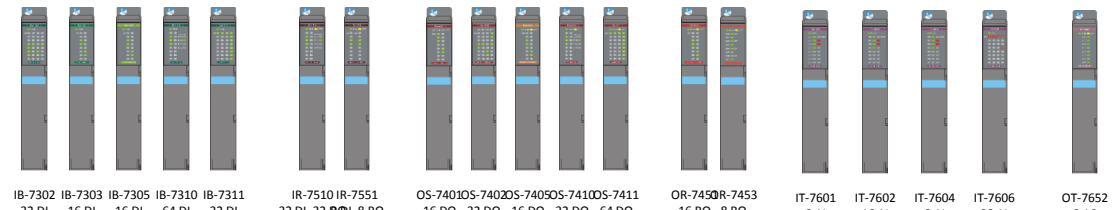
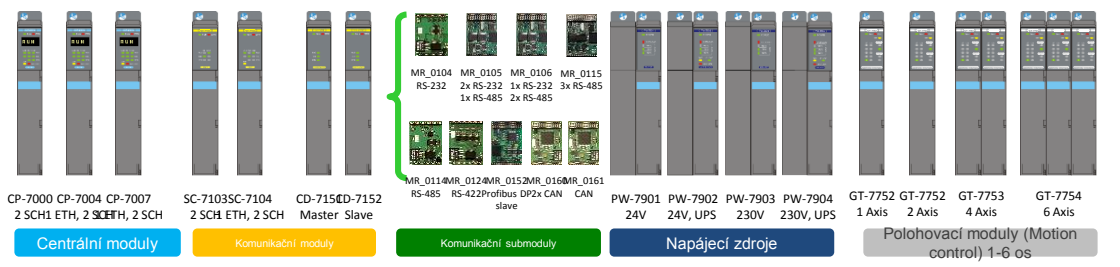
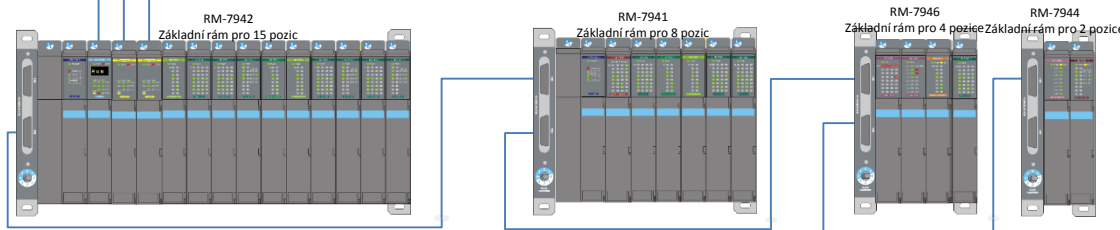
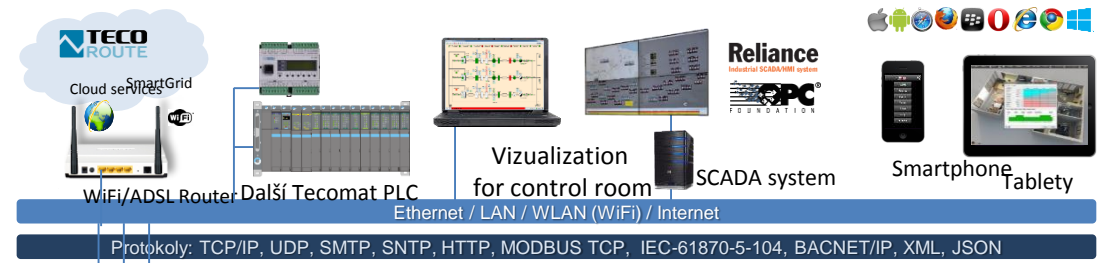

## Mosaic – volné programování - IEC 61131-3

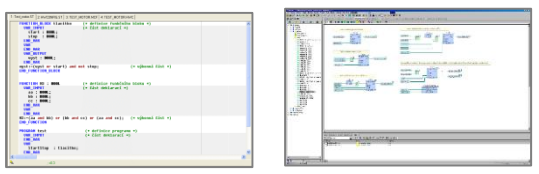

ST – Structured Text  
FC – Continuous Flow Chart

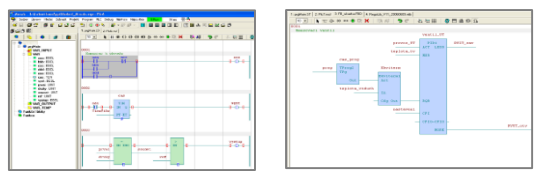

LD – Ladder Diagram – reléové schéma

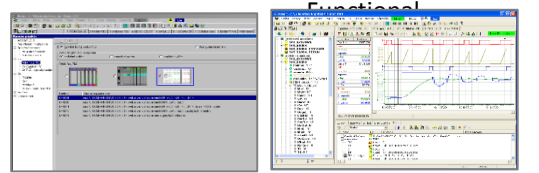

Target PLC konfigurator  
GraphMaker – signal visualisation

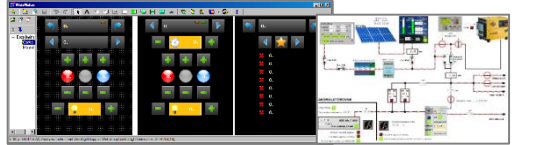

WEB Maker – tvorba vlastních stránek



Firmware Updater



DataLogger

## Tecomat Foxtrot – Přehled systému



Ethernet / LAN / WLAN (WiFi) / Internet

TCP/IP, UDP, SMTP, SNT, HTTP, MODBUS TCP, IEC-61870-5-104, BACNET/IP, XML, JSON

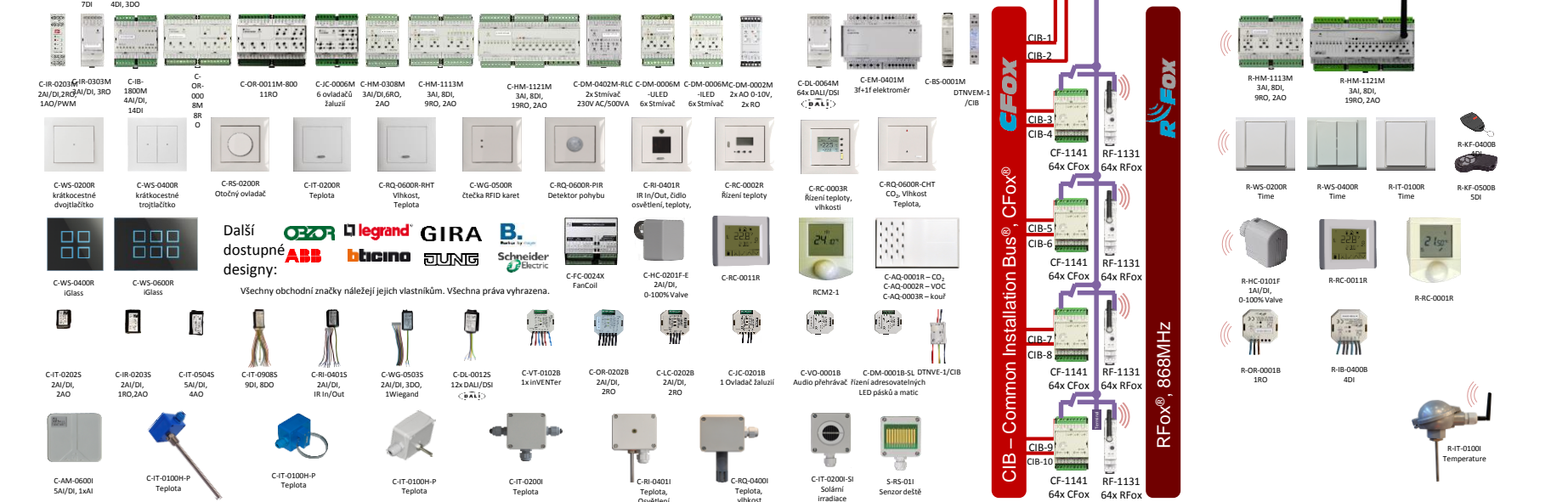
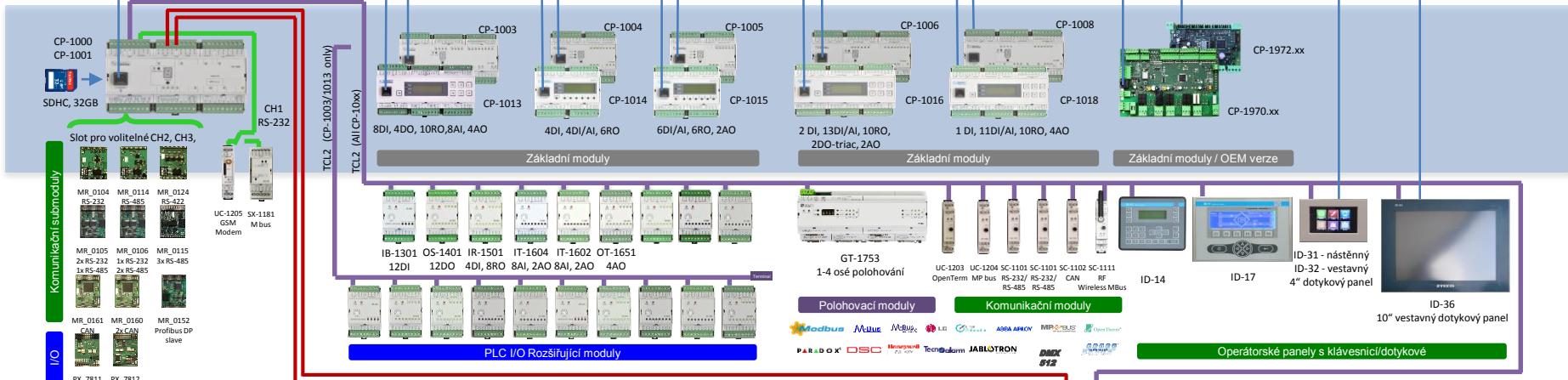



## Tecomat Foxtrot – Přehled systému

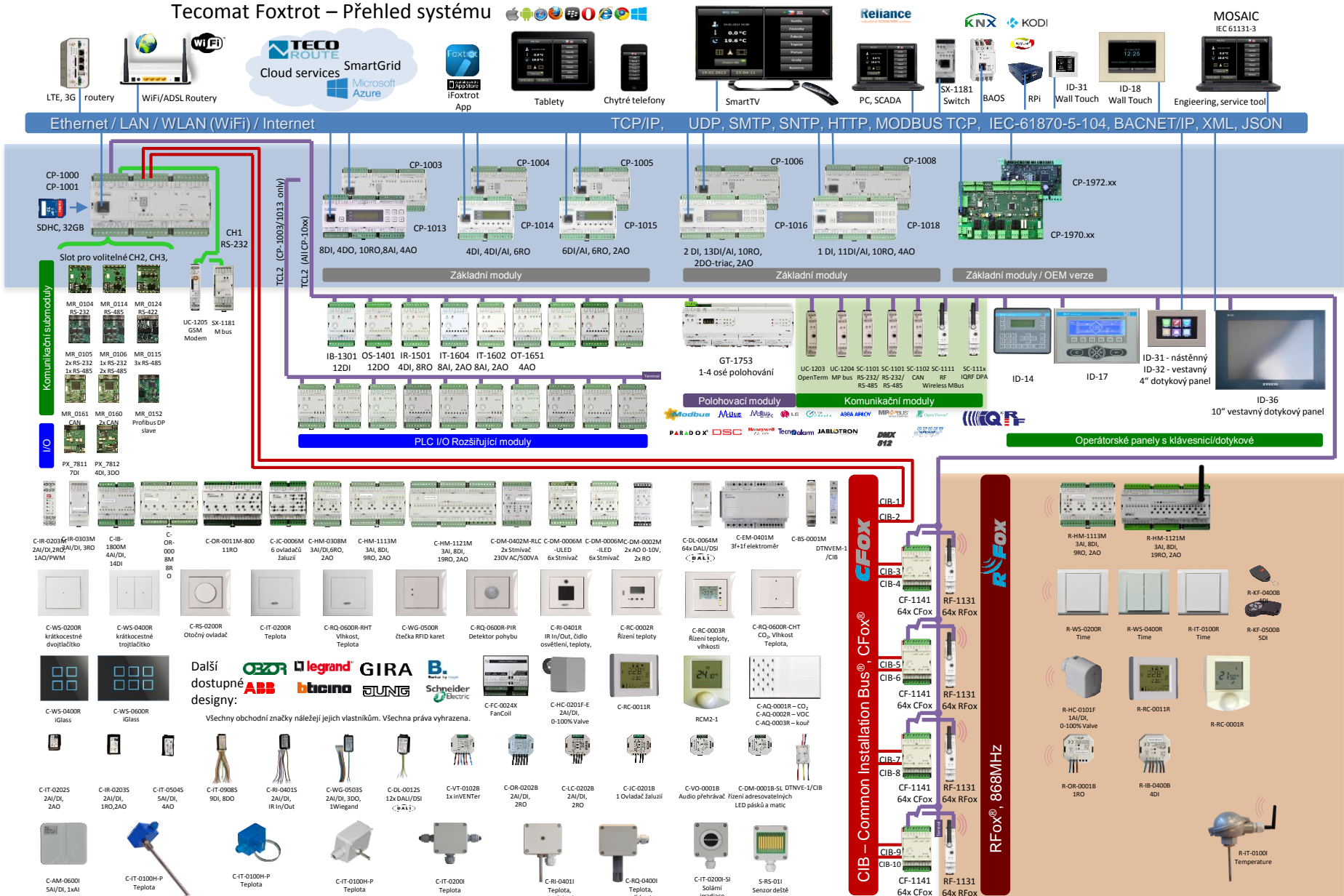



Tisíce mobilních aplikací na tisíce senzorů



Internet věcí = stovky nekompatibilních internetů věcí

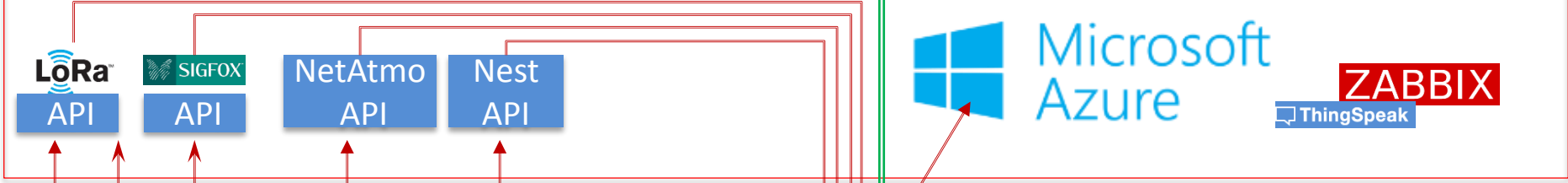

Cloud



Fog

Local powerfull server = Foxtrot = Gateway

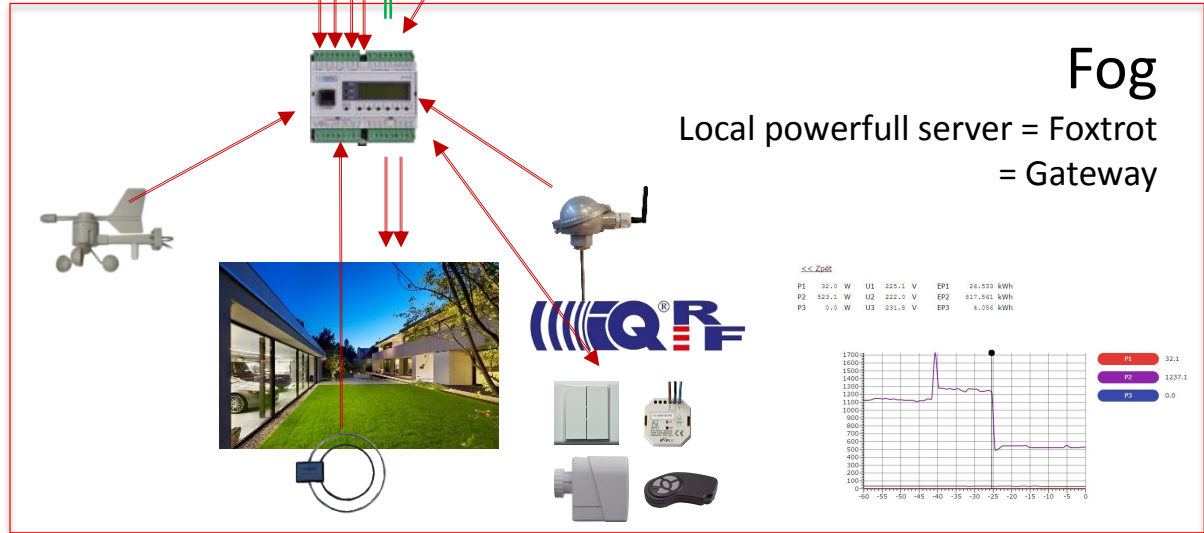

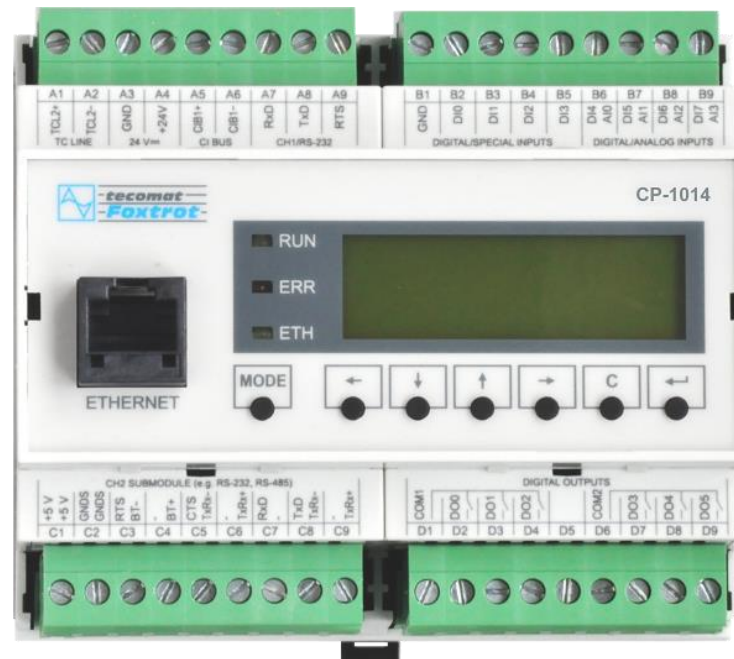
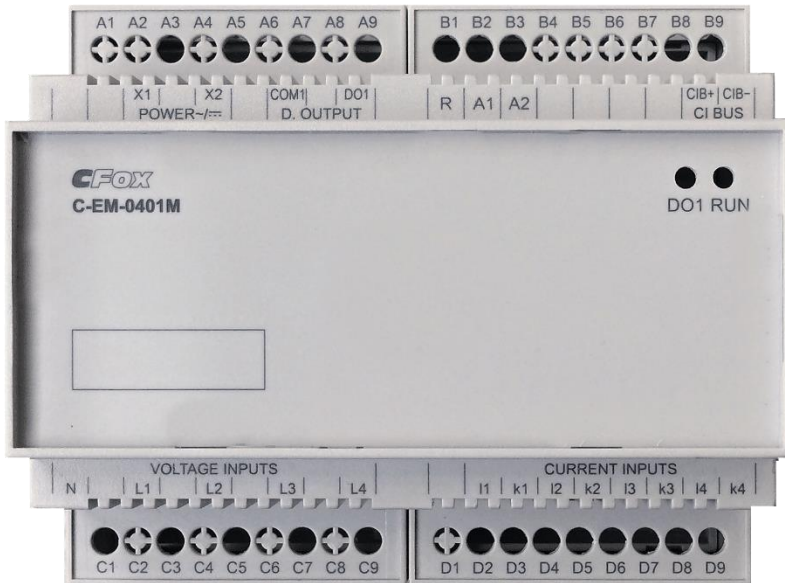



<< Zpět

P1	32.0	W	U1	225.1	V	EP1	26.533	kWh
P2	523.1	W	U2	222.0	V	EP2	817.561	kWh
P3	0.0	W	U3	231.8	V	EP3	4.056	kWh

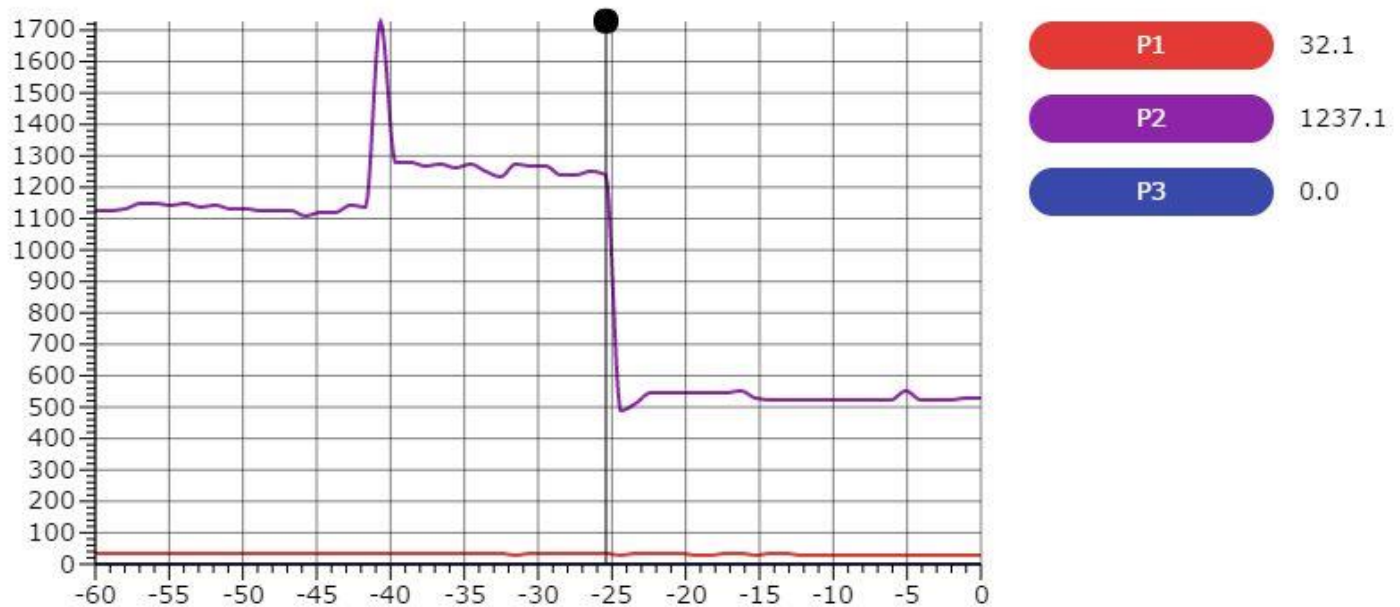

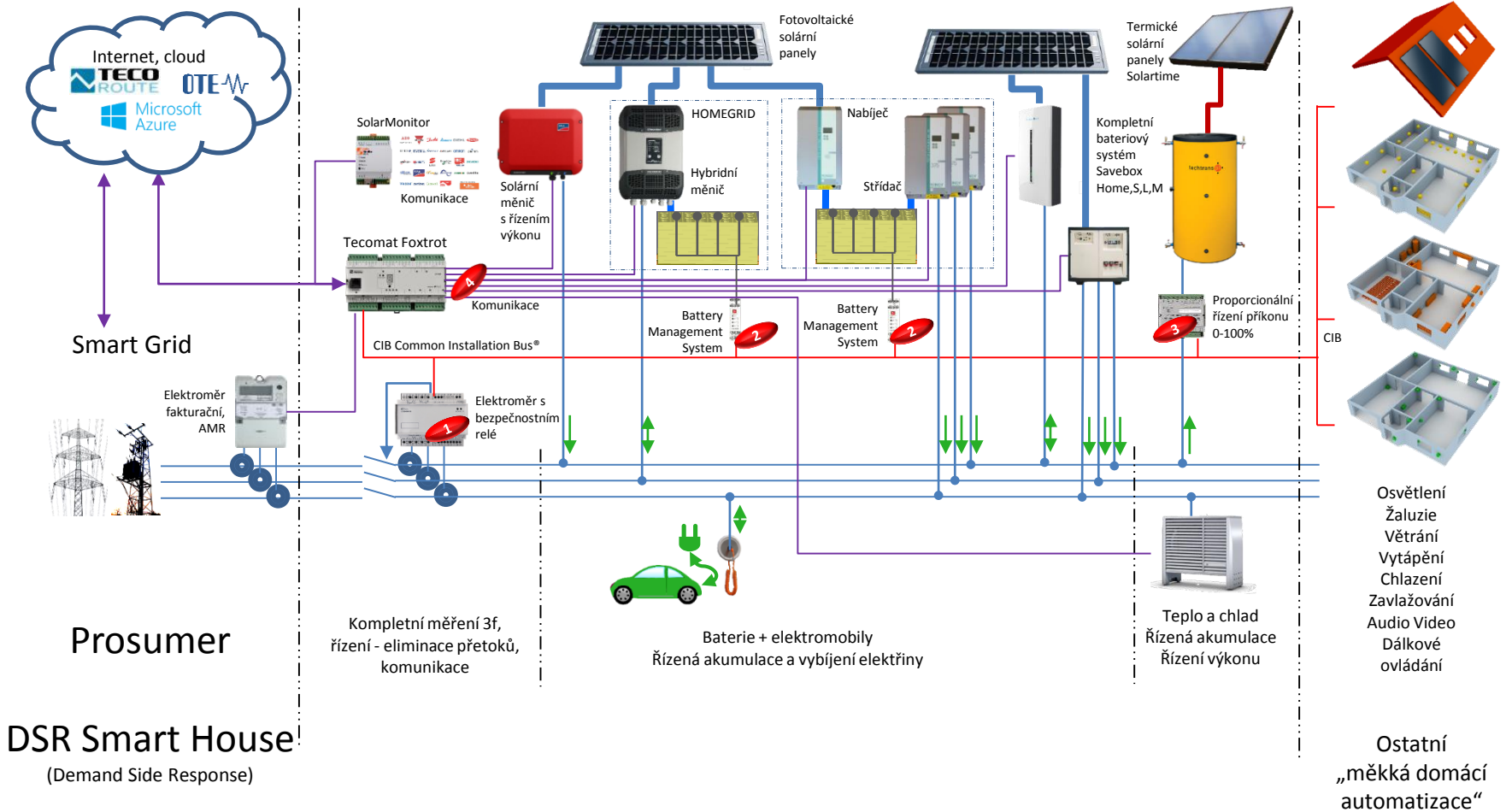

## Prosumer in Smart Grid

Machines for automotive

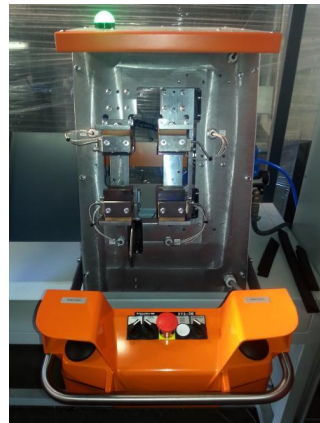

Bio Energo plant





## Building automation – centralized wireless control of radiator valves



## Transport – D5 highway tunnel full control

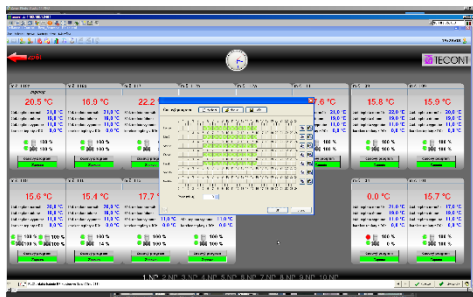



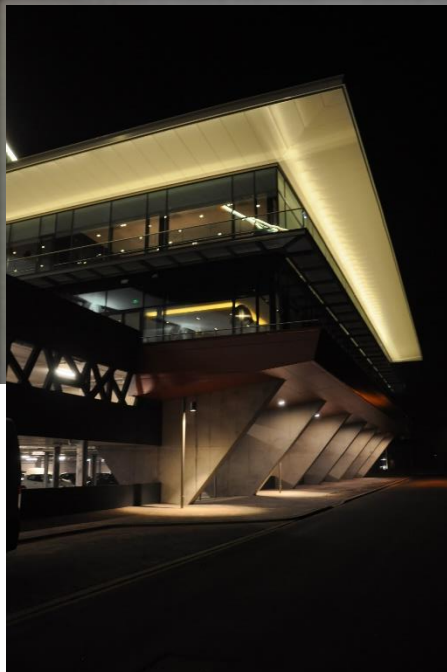





Zakrytovaný rozvaděč v RD



Částečně odkrytý rozvaděč v RD

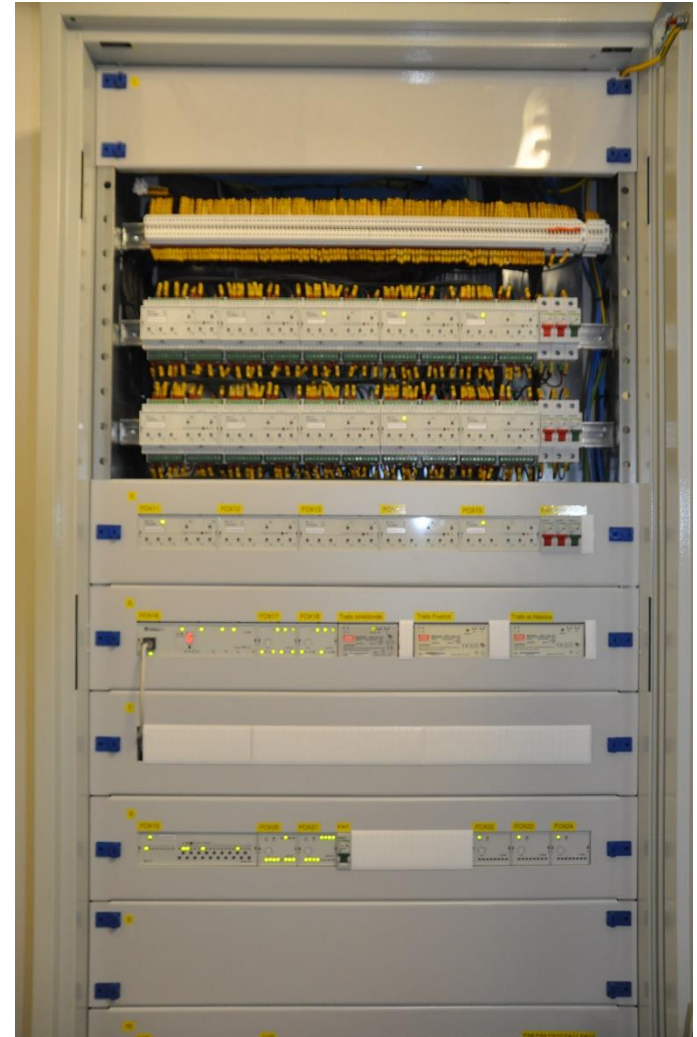



# Foxtrot for heating

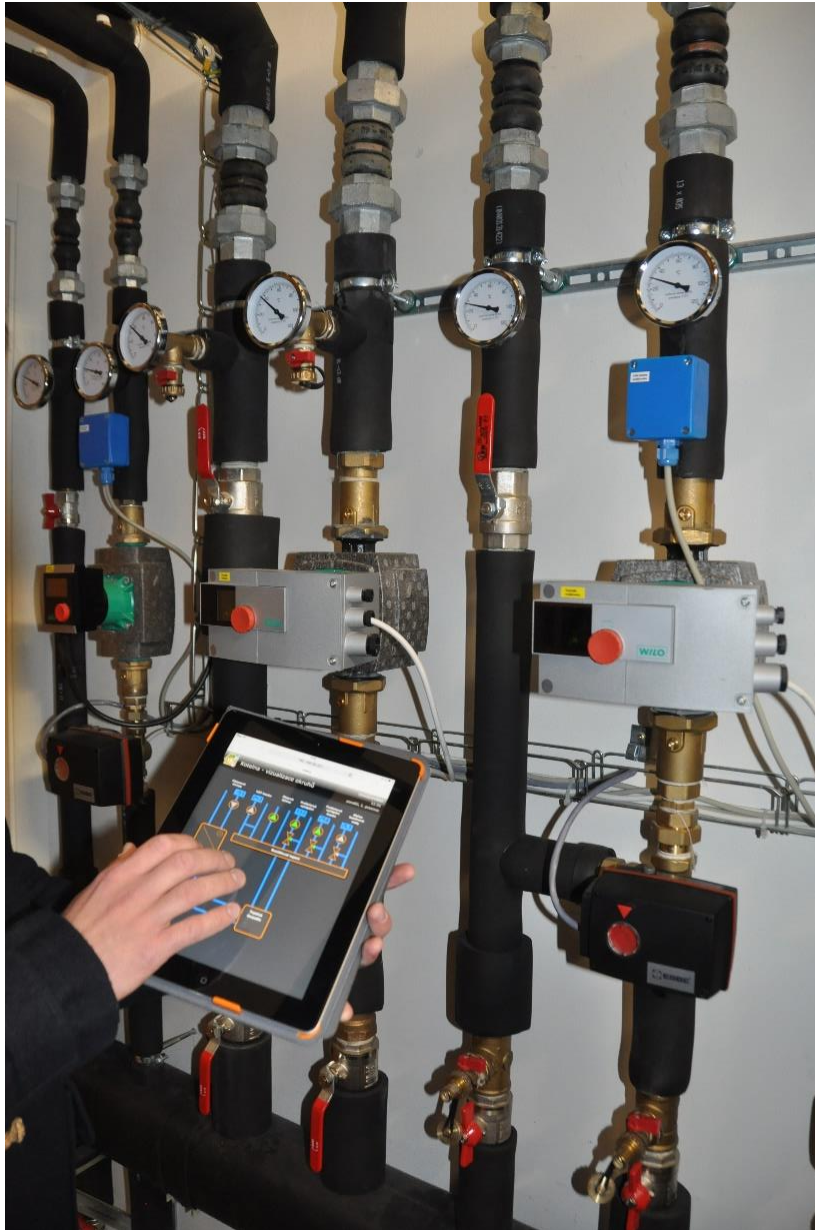

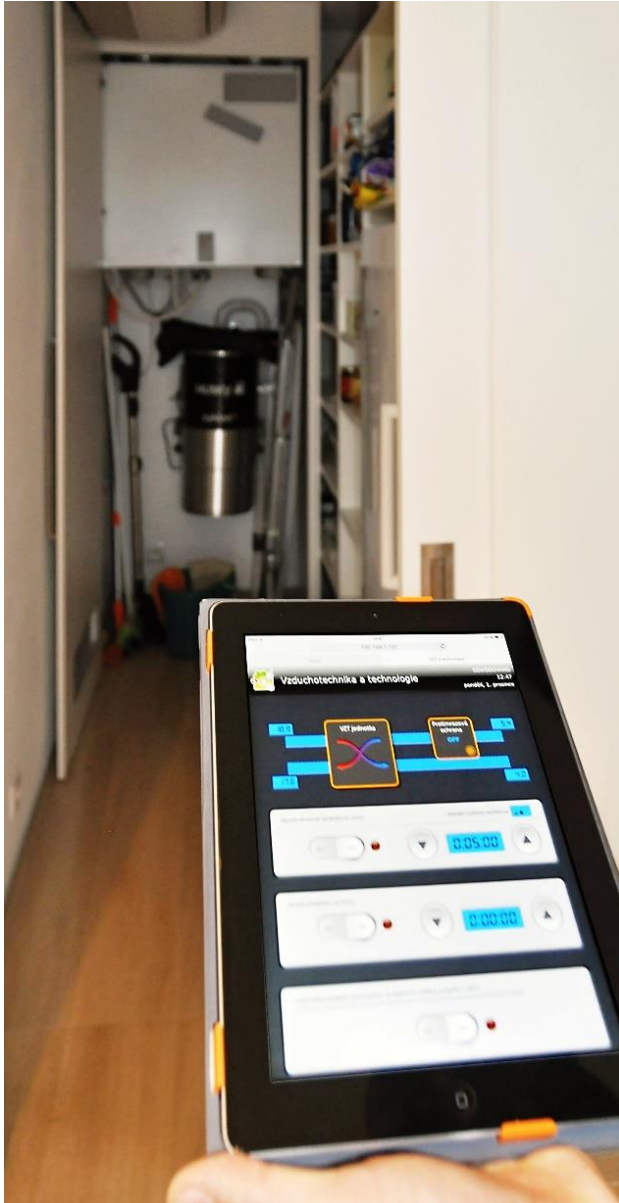



# Foxtrot for lighting and shading

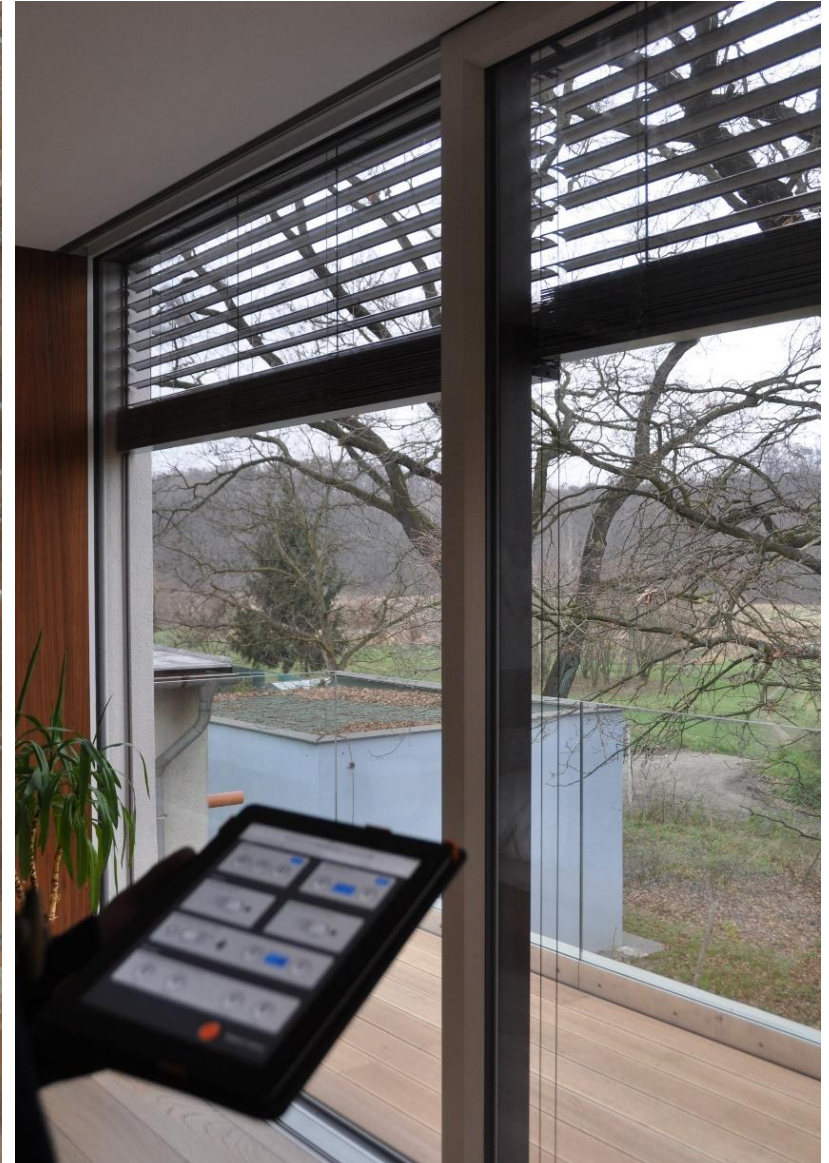



Hotel  
Van Der Valk  
Veenedaal,  
Holandsko



Rodinný dům  
Düsseldorf,  
Německo



Domy  
Ecomodula,  
Francie



Hotel  
My Story,  
Lisabon,  
Portugalsko



Český pavilon  
EXPO 2015  
Milano,  
Itálie



Showroom,  
Sao Paulo,  
Brazílie



Sběr dat  
z plynoměrů,  
Istanbul, Turecko



Museum  
kyperského divadla,  
Limasol, Kypr



Měření a regulace  
Smith Medicals,  
Česká republika



Apartment Tri veze,  
Bratislava, Slovensko



Rodinný dům,  
Maďarsko



Vzduchotechnika  
VBW, Gdaňsk  
Polsko



Vila na ostrově Korfu  
Řeco



Liberty  
Technology  
Park, Cluj ,  
Rumunsko



Kotelna  
na biomasu,  
Kohila  
Estonsko



Kotelna,  
Lvov  
Ukrajina



Parkoviště  
Tichin,  
Jekatěrínburg  
Rusko



Klimatizace  
společenského  
sálu,  
Astana,  
Kazachstan



Samsung,  
výroba LED  
display  
Korea



Certifikace  
v procesu



Certifikace  
v procesu



Nemocnice Jeddah  
Saudská Arabie



Překladiště ropy,  
Black sea terminal,  
Poti, Gruzie.



110 km přivaděče vody,  
Larestan, Irán



Výroba rozvaděčů,  
Indie

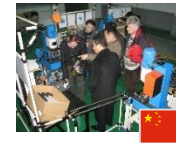

Výroba autodílů, Čína



MVE Fujishida,  
Japonsko









# Foxtrot on the ocean - SLIM - Gunboat 55

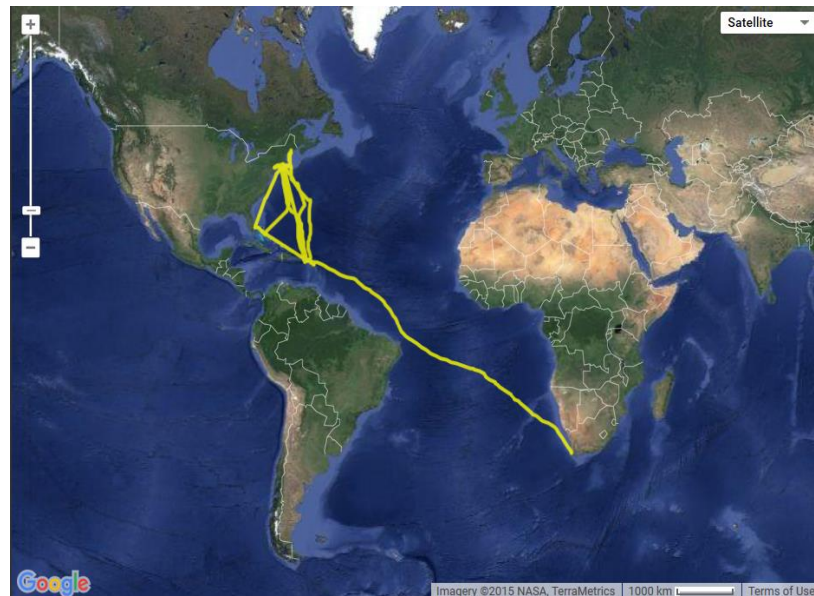
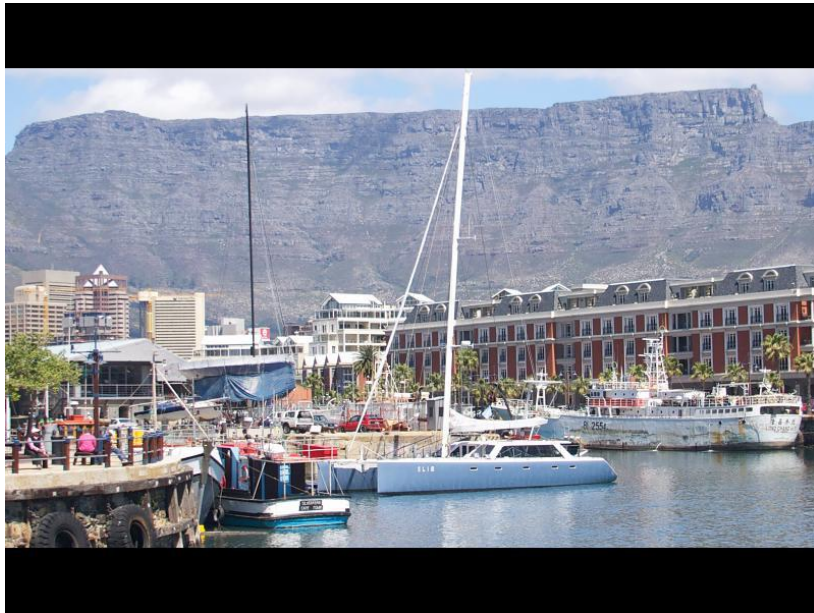

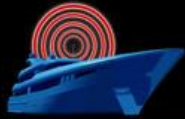

**Commander**

**CRP12**

**Outlets**

Group = OFF

Port Gally Outlets

Stb Outlets

Saloon Outlets

**Water**

Group = OFF

Port Heater

Stb Fwd Heater

Stb Aft Heater

**230 Volt Control & Devices**



**Air Condition**

Group = OFF

Stb Air Condition

Port Air Condition

**House Appliances**

Group = OFF

Oven & Hob

Washing Machine

Dish Washer

Quick Hot Water

Micro Wave

Water Maker

230V - 115V

Dive Compressor

Instruments

**Main Power**

Pumps

Winches

Lights 1

Lights 2

Specials

Climate

Refrigerators







# Commander

CBP12



## Service Battery

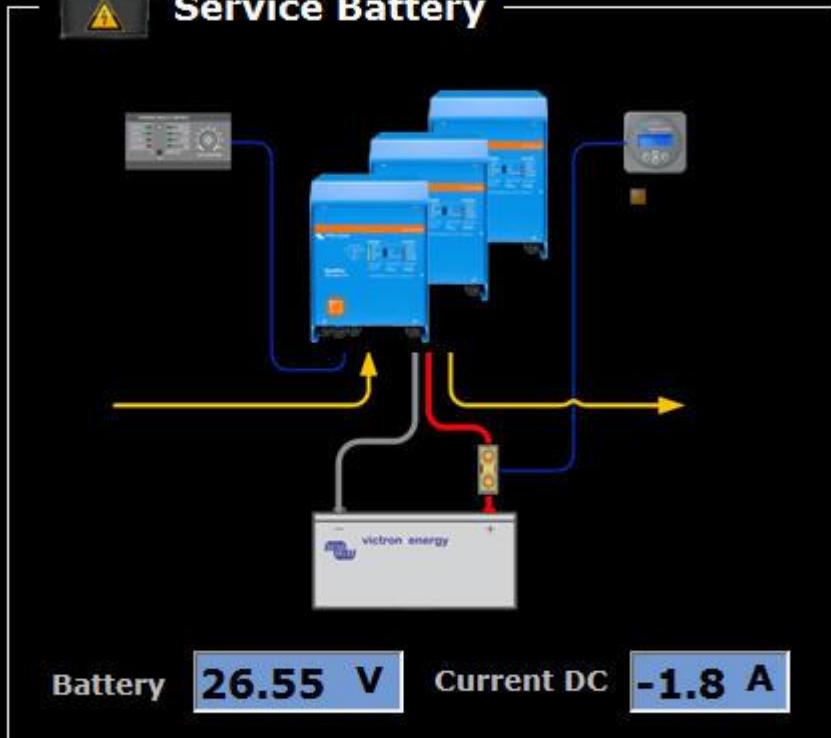

## Battery Info

- State of Charge **112 %**
- Time to Go **243**
- Consumed Energy **-4.30**
- Day since last full charge **86.29**
- Times of auto synchronized **5 x**
- Total Amp Hours from battery **-44.83**

Start

Status

Control

Climate

**24 Volt**

230 Volt

Info

## WEB VIZUALIZACE



## SYSTÉMY ZALOŽENÉ NA FOXTROTU



## TEPELNÁ ČERPADLA



## VĚTRÁNÍ, REKUPERACE



## TOPENÍ



## SCADA, VIZUALIZACE



## KLIMATIZACE



## SOLÁRNÍ MĚNIČE



## NÁSTĚNNÉ OVLADAČE



## OSTATNÍ NÁSTĚNNÉ OVLADAČE



## APP, WEB, CLOUD SLUŽBY



## ZABEZPEČENÍ A PŘÍSTUPY



## AUDIO VIDEO SYSTÉMY



## DOMÁCÍ SPOTŘEBIČE, OSVĚTLENÍ



## OSVĚTLENÍ, STÍNĚNÍ



Process and Factory Automation

SmartGrid, Smart Metering

Smart House Building Automation

SmartCity GeoPortal



AVE 2 PROJECT

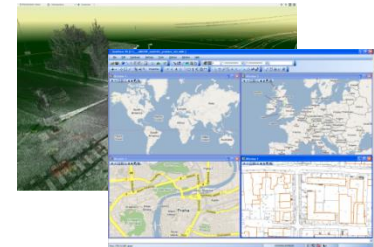

**TECO**  
ROUTE

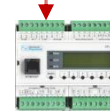
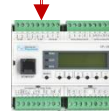



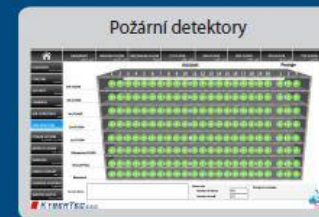
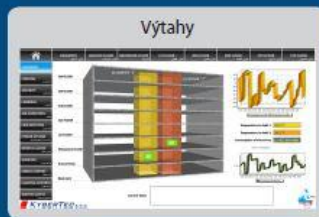
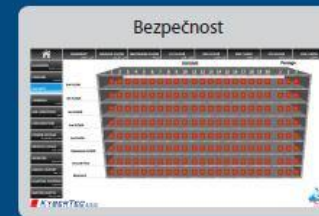
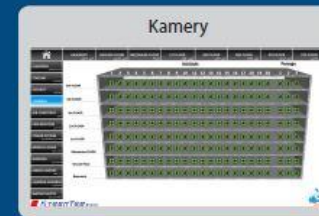
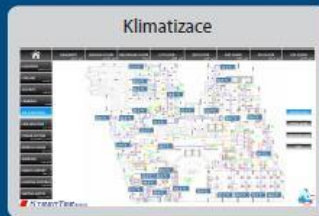



**Reliance**  
Industrial SCADA/HMI system

Chytrý dům



Knihovny, správní budovy



Městský geoportál



Lokální distribuční soustavy



Městské atrakce, mobiliář



**Marushka**  
AVE 2 PROJECT

CZT kotelny



Vodárenská síť



Plynárenská síť



Fotovoltaika, akumulace



Distribuční síť



## Chytré město

chytré budovy | chytrá doprava | chytrá rozvodná síť | chytrý život



Kamerové systémy



Veřejné osvětlení



Chytré zastávky



Půjčovny elektrokol



Půjčovny elektromobilů



Zde můžete mít  
i projekt z vašeho  
města nebo obce!

Dopravní detektory



Info pro řidiče



Monitoring parkovacích míst



Rízení tunelů



Nabíjecí stanice, elektromobilita



Internet věcí  
**SIGFOX**  
Alliance

## Parkovací místa

**VOLNO**

**3**

Aktuální počet volných míst

**OBSAZENO**

**4**

Aktuální počet obsazených míst

### Celková obsazenost parkovacích míst

Celková obsazenost parkovacích míst

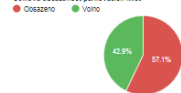

### Aktuální obsazenost jednotlivých parkovišť

Aktuální obsazenost jednotlivých parkovišť



### Souhrnný vývoj teploty parkovacích ploch

Časový vývoj teplotních průměrů a extrémů parkovacích ploch (°C)

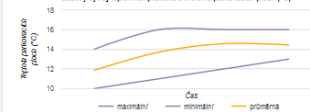

### Historie celkové obsazenosti

Historie celkové obsazenosti

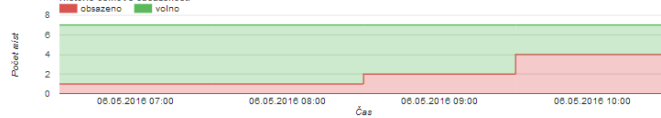

### Mapa - volná parkovací místa

### Mapa - obsazená parkovací místa

### Přehled parkovacích míst

Záznamů na stránku: 3

Filtr:

Lokalita	ID Parkovacího místa	Obsazenost	Teplota povrchu	Čas
Parkovací ulice	1	Volno	13 °C	06.05.2016 10:00
Parkovací ulice	2	Obsazeno	16 °C	06.05.2016 10:00
Parkoviště u lípy	1	Obsazeno	15 °C	06.05.2016 10:00

Stránka 1 / 3

Předchozí 1 2 3 Další

### Tabulkový přehled parkovacích míst

Tabulka zobrazuje poslední zaznamenaný stav jednotlivých parkovacích míst. V rámci záznamů je možné vyhledávat dle zadaného textového řetězce nebo řadit vzestupně/ sestupně dle vybraného sloupce.





# ZPI-811 - 1. Cínovecká

**Simulace**

PIT **Dveře otevřeny**

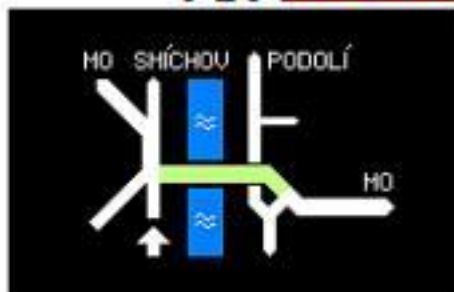

## GS

Přepětová ochrana	O.K.
Hlavní jistič	O.K.
Přepětová ochrana PLC	O.K.
Jistič 24V	O.K.
Jistič PIT	O.K.

Jistič PDZ	PORUCHA
Jistič topení	O.K.
Jistič ventilace	O.K.
Jistič zásuvky	O.K.
Dveře	OTEVŘENY

## SMO

C

Tlačítko 1	-----
Tlačítko 2	-----
Tlačítko 3	-----
Tlačítko TEST	-----
Přepínač	ZAPNUTO
Přepínač	DÁLKOVĚ
Dveře	OTEVŘENY



- Central point for local wireless network  
with full local control, logger and visualization capability
- Central point with safe and secured connectivity into internet and cloud without public IP  
– TecoRoute
- M2M Connectivity of Foxtrot via Internet for smart metering and Internet of Things

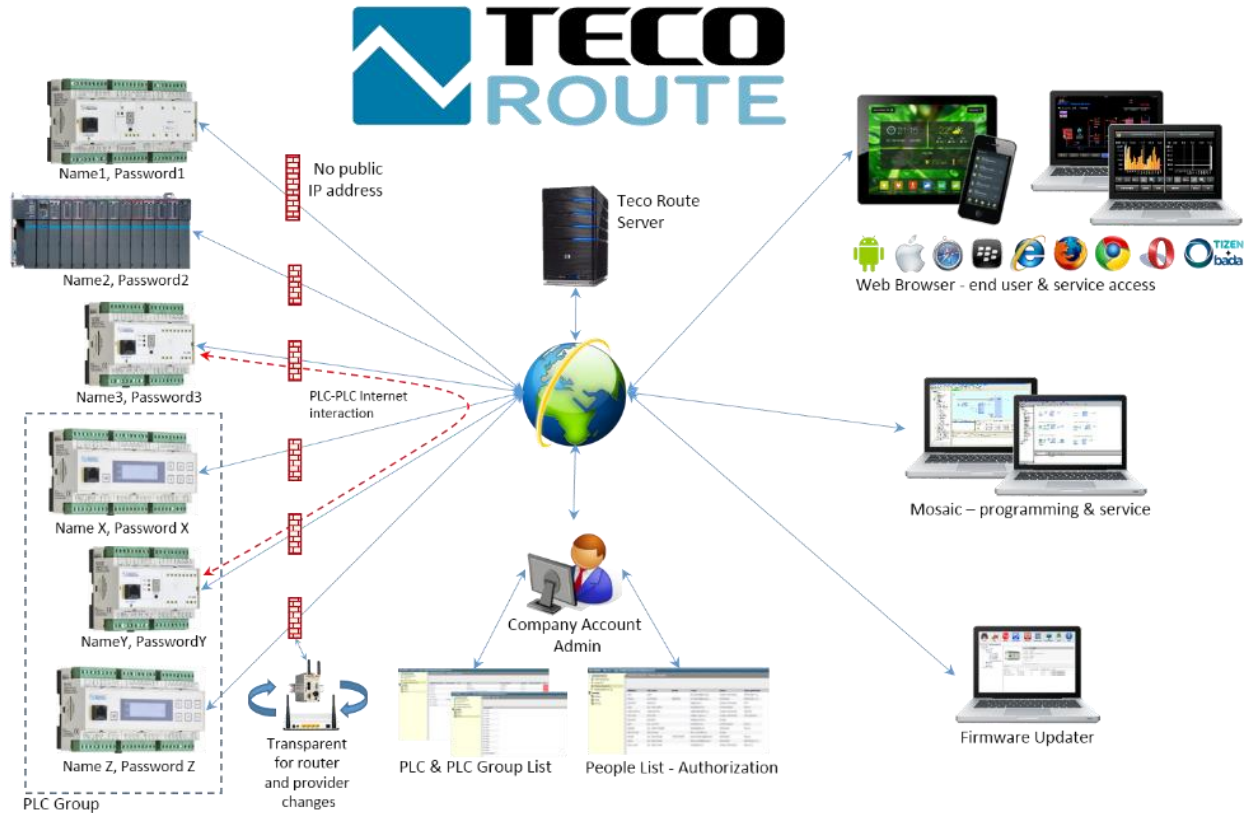

- Projects for integration their wireless peripherals into the Foxtrot system to be offered together as standard or specific solution
  - sensors, actors, dimmers, loggers etc.
- Projects and cases in building/city automation, energy management, machine and proces control and other, where wireless network and local centralized control with secured remote access is required
- Pojects and companies who are looking for OEM supplier for their control solutions



Thank you for attention

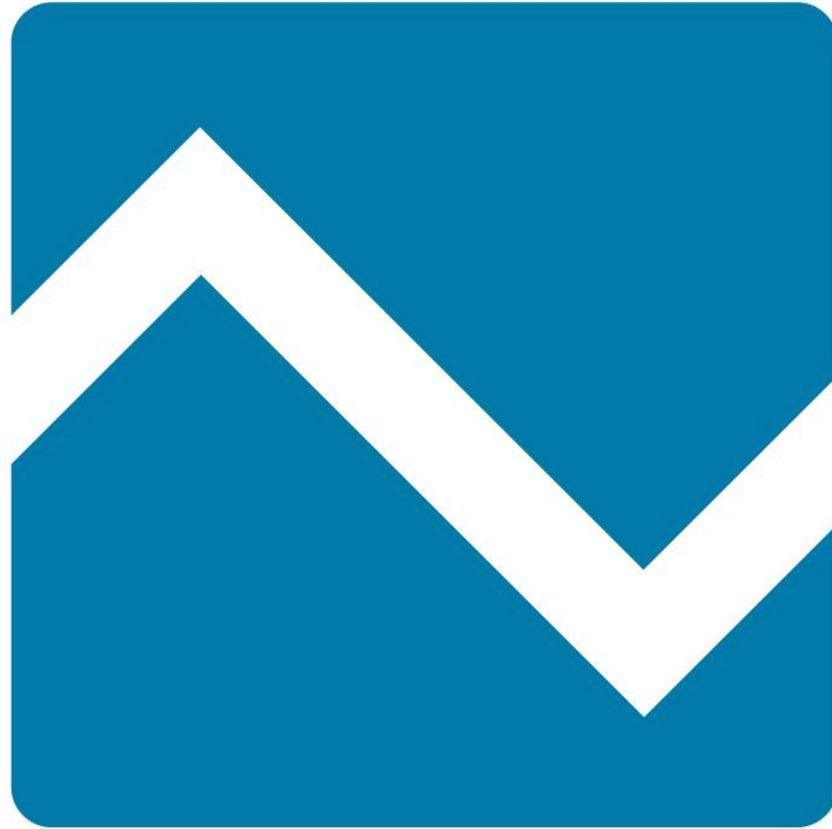

**TECO**